



The future is clean air ... the future is **Sourcetec**

www.sourcetecindustries.com E-mail: sales@sourcetecindustries.com

Tel: (905) 678-9333 1-800-784-2383 Fax: (905) 678-7133

## TECHNICAL INFORMATION

This drawing is the sole property of Sourcetec Industries Inc. We reserve the right to change specifications and details without prior notice. Unauthorized duplication, distribution or use by a third party is strictly prohibited.

### SOURCETEC SERIES "WBDT" WELDINGBENCH DOWNDRAFT TABLE

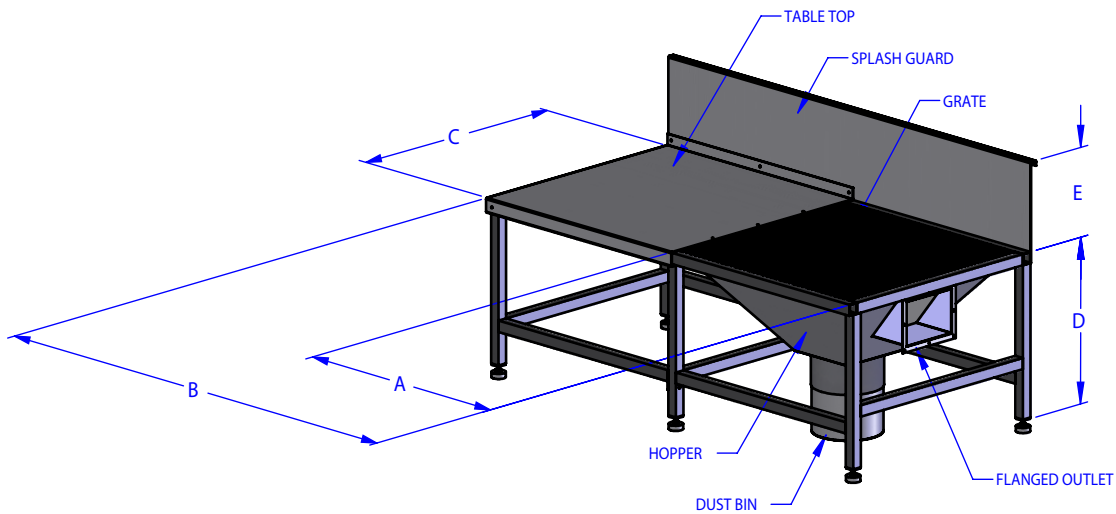

MODEL	A	B	C	D	E
	In. (mm)	In. (mm)	In. (mm)	In. (mm)	In. (mm)
WBDT-4808	48 (1219)	96 (2438)	48 (1219)	30 (762)	16 (406)
WBDT-4812	48 (1219)	144 (3658)	48 (1219)	30 (762)	16 (406)
WBDT-4816	48 (1219)	192 (4877)	48 (1219)	30 (762)	16 (406)

\* Dimensions are for reference only

#### APPLICATIONS:

- Plasma Cutting
- Welding
- Metal Fabrication shops
- General Fume and Dust

#### STANDARD FEATURES:

- Heavy Duty Tubular Steel Frame
- Steel top with Splash Shield
- Adjustable Levelling Feet
- Frame is coated with Black Epoxy Finish
- Grate Section with Hopper and Bin

#### OPTIONAL FEATURES:

- Available in other materials
- Custom sizes are available
- Frame finish available in different colors.



*The future is clean air ... the future is Sourcetek*

www.sourcetekindustries.com E-mail: sales@sourcetekindustries.com

Tel: (905) 678-9333 1-800-784-2383 Fax: (905) 678-7133

## TECHNICAL INFORMATION

This drawing is the sole property of Sourcetek Industries Inc. We reserve the right to change specifications and details without prior notice. Unauthorized duplication, distribution or use by a third party is strictly prohibited.

### SOURCETEC SERIES “WBH” WORK BENCH - HEAVY DUTY

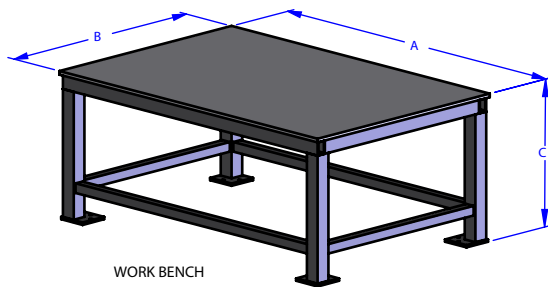

WORK BENCH

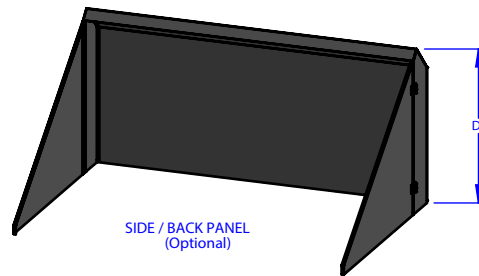

SIDE / BACK PANEL  
(Optional)

MODEL	A	B	C	D
	In. (mm)	In. (mm)	In. (mm)	In. (mm)
WBH-3036	36 (914)	30 (762)	31 (787)	36 (914)
WBH-3048	48 (1219)	30 (762)	31 (787)	36 (914)
WBH-3072	72 (1829)	30 (762)	31 (787)	35 (904)

\* Dimensions are for reference only

#### APPLICATIONS:

- Welding
- Metal Fabrication shops
- Industrial Facilities

#### STANDARD FEATURES:

- Heavy Duty Tubular Steel Frame
- Steel work top
- Heavy Duty Side/Back Panels
- Frame is coated with Black Epoxy Finish

#### OPTIONAL FEATURES:

- Available in other materials
- Custom sizes are available
- Frame finish available in different colors.



*The future is clean air ... the future is Sourcetec*

www.sourcetecindustries.com E-mail: sales@sourcetecindustries.com

Tel: (905) 678-9333 1-800-784-2383 Fax: (905) 678-7133

## TECHNICAL INFORMATION

This drawing is the sole property of Sourcetec Industries Inc. We reserve the right to change specifications and details without prior notice. Unauthorized duplication, distribution or use by a third party is strictly prohibited.

### SOURCETEC SERIES "WB" WELDING BENCH

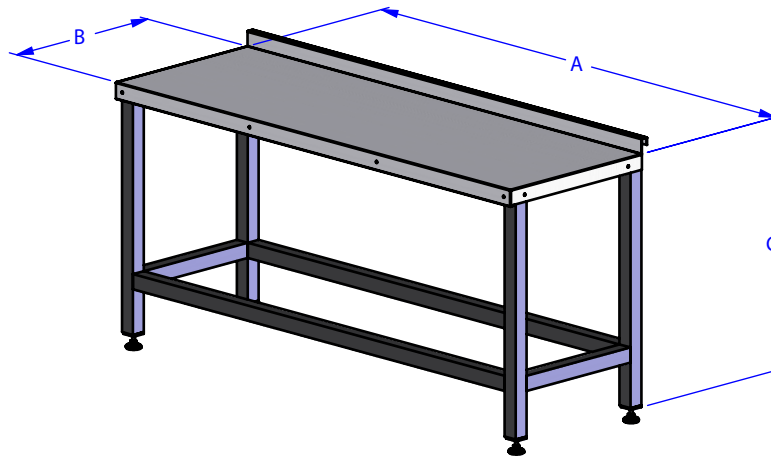

MODEL	A	B	C
	In. (mm)	In. (mm)	In. (mm)
WB-3036	36 (914)	30 (762)	35 (889)
WB-3048	48 (1219)	30 (762)	35 (889)
WB-3072	72 (1829)	30 (762)	35 (889)

\* Dimensions are for reference only

#### APPLICATIONS:

- Industrial Facilities
- Welding
- Metal Fabrication shops
- Educational Facilities

#### STANDARD FEATURES:

- Heavy Duty Tubular Steel Frame
- Steel work top
- Adjustable Levelling Feet
- Frame is coated with Black Epoxy Finish

#### OPTIONAL FEATURES:

- Available in other materials
- Custom sizes are available
- Frame finish available in different colors.