

### Standard Features

- Can be combined for larger sizes
- Positive seal keeps leakage below 1%
- Available in any combination of width or height
- Damper motor (factory installed) (24, 115 or 230V)( 1 required every 8 sq.ft. of louvre area)
- Chain operation
- Roll form or extruded blade
- Double panel available 30" and up

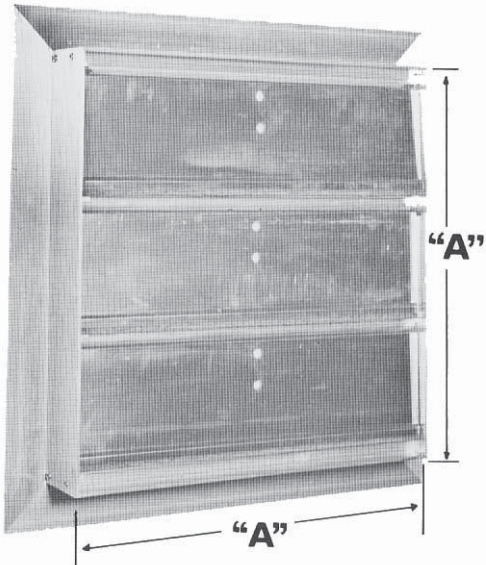

Motorized Dampers Series "MD"

### Blade Options

- RF - .016" – 0.20" roll formed
- Aluminum with silicon
- Impregnated felt edge
- XB - .050" Extruded Aluminum with vinyl gasket

### Ordering Instructions

Use dimension "A" – give full description  
(i.e. Series 31 – 22W x 14H – Extruded Blade – Motorized – 115V)

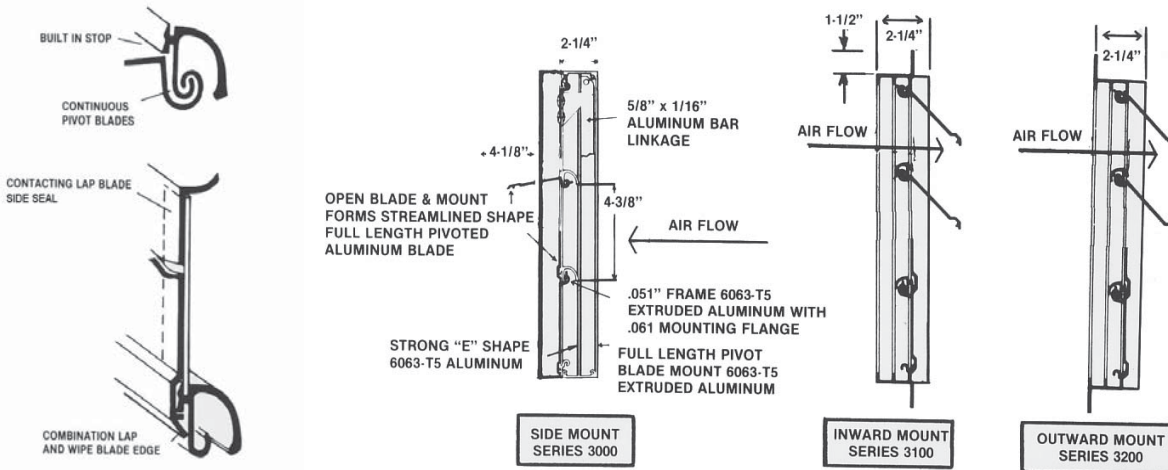

Distributed by:

## Model BD01, BD02, BD03: Back Draft Dampers



- Sturdily constructed from all-aluminum extrusions.
- Roll form blades or extruded aluminum blades.
- Available in any combination of width and height.
- Less than 1% leakage.

Series BD01  
Side Mount  
(No Flange)



Series BD02  
Inward Mount

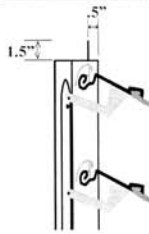

Series BD03  
Outward Mount

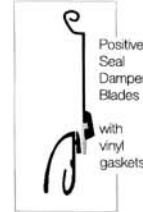
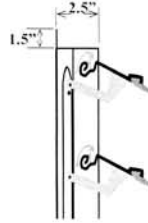

### Blade Options

RF: 0.016" - 0.020" roll formed aluminum with vinyl gasket

XB: 0.05" Extruded aluminum with vinyl gasket

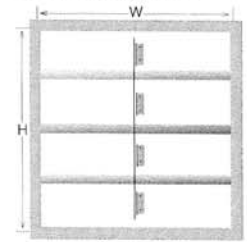

### Ordering Method

Use dimensions W x H with FULL details (flange dimensions are NOT included)

### Example

Model BD02 22W x 14H Extruded Blade

## Model MBD01, MBD02, MBD03: Motorized Back Draft Dampers

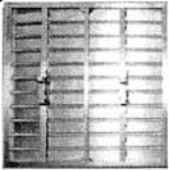

- Sturdily constructed from all-aluminum extrusions.
- Damper motor factory installed (24V, 115V or 230V must specify at time of order).
- Maximum 8 sq feet per motor.
- Positive seal keeps leakage less than 1%.
- Blades are .05" extruded aluminum with vinyl gasket.
- Double Panel available 30" and up.

Model MBD01  
Side Mount  
(No Flange)

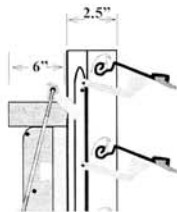

Model MBD02  
Inward Mount

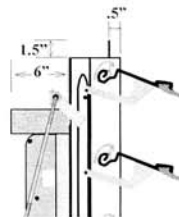

Model MBD03  
Outward Mount

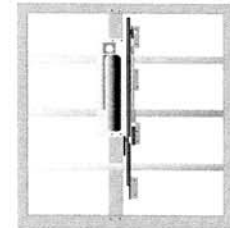
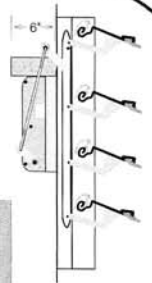
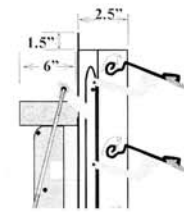

### Ordering Method

Use dimensions W x H with FULL details (flange dimensions are NOT included)

### Example

Model MBD02 22W x 14H 115V Motor