

EHC Model HT

Exhaust filter for diesel or gas engines

EHC HT filters are designed for permanent use on diesel or gas engines and are available in stainless steel and alu zinc. The filters work from immediate start up of the vehicle and are insensitive to humidity.

All filters are delivered with:

- filter
- drain tap for condensed water
- flanges on inlet and outlet
- feet, flexible
- heat shield
- cover with eccentric locks (easy to change filter)
- pressure switch control lamp and buzzer to warn the driver when filter and/or membrane needs to be replaced.

Application

EHC HT exhaust filter is recommended when people are confronted with running diesel or gas exhaust in confined spaces.

For building machinery, heavy vehicles, industrial machines and forklift trucks.



Technical Data

Separation:

reduces in room
>95% of 0,4 μ particles or larger. Even mutagenic, carcinogenic and allergy producing substances which attach to particles.

	Exhaust volume, max	Imperial
EHC HT35	35 m ³ /min	1236 ft ³ /min
EHC HT20	20 m ³ /min	706 ft ³ /min
EHC HT10	10 m ³ /min	353 ft ³ /min

	Temperature, max	Imperial
	250°C	482°F

Filter life

EHC HT35 ~ 200 hours
EHC HT20 ~ 200 hours
EHC HT10 ~ 100 hours

The lifetime is dependent on the engine size, engine type, how it is used and engine condition.

	Weight	LBS
EHC HT35 complete	40 kg	88 lbs.
EHC HT20 complete	23 kg	51 lbs.
EHC HT10 complete	18 kg	40 lbs.

EHC HT meets the TRGS 554 (D), COSHH (GB) regulation and VERT Filter List (CH).
The filter is disposable in normal waste.

3-way valve

When EHC HT is for dual use (inside & outside) a three-way valve can be mounted in front of the filter. This makes it possible for the filter to be switched off when driving outside.

The EHC 3-way valve can be manual or electric. When electric the driver can control the valve from the driver's seat. A control lamp will indicate which position the valve is in.

It's also possible to make the valve command fully automatic. This is done by using sensors that will open and close the valve when the vehicle leaves or enters a building.



Technical Drawings

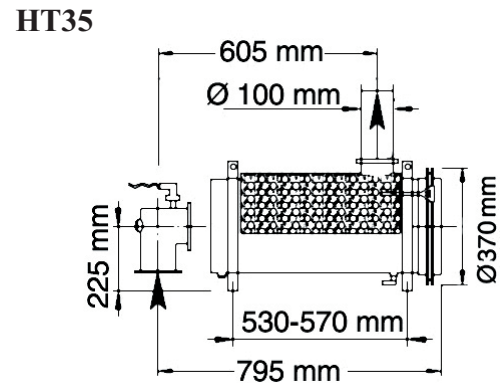
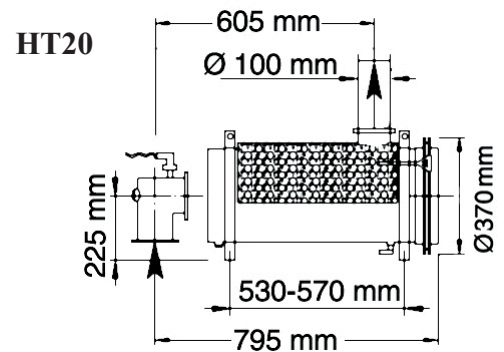
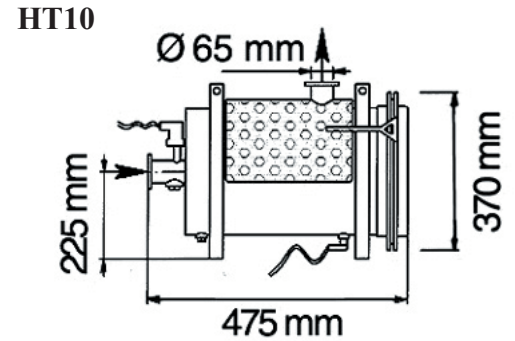

Formula to calculate right model of EHC HT

$$(\text{Cylinder vol(litre)} \times \text{rpm} \times \text{efficiency}^*) / 2000 = \text{Air consumption (N3/min)**}$$

$$(\text{Air consumption} \times (\text{exhaust temp} + 273)) / 293 = \text{Exhaust volume (m3/min)}$$

*Efficiency

Aspirating engine = 0.85

Turbo engine = 1.70

Turbo with intercooler = 1.85

** (N3: Normal cubic metre)



The future is clean air ... the future is Sourcetec®

Mississauga, Ontario, Canada

Tel: (905) 678-9333 Fax: (905) 678-7133

Holland, Ohio, USA

1-800-784-2383

www.sourcetecindustries.com E-mail: sales@sourcetecindustries.com